

CE / EMC Test Report

Report Reference No..... : AIT21062802E

Applicant's name..... : Dongguan junda new energy technology.Co.Limited

Address..... : Room 601, Building 3, No.12, Futang Street, Dalingshan Town,
Dongguan City, Guangdong Province

Manufacture's Name..... : Dongguan junda new energy technology.Co.Limited

Address..... : Room 601, Building 3, No.12, Futang Street, Dalingshan Town,
Dongguan City, Guangdong Province

Product name..... : Lithium ion Battery

Trademark : N/A

Model and/or type reference..... : JD-LK48-10

Rating(s)..... : 48V 10Ah

Testing Laboratory information:

Testing Laboratory Name : Dongguan Yaxu (AiT) Technology Limited

Address : No. 22, Jinqianling Third Street, Jitigang, Huangjiang, Dongguan,
Guangdong, China.

This device described above has been tested by Dongguan Yaxu (AiT) Technology Limited, and the test results show that the equipment under test (EUT) is in compliance with the CE requirements. And it is applicable only to the tested sample identified in the report.

This report shall not be reproduced except in full, without the written approval of Dongguan Yaxu (AiT) Technology Limited, this document may be altered or revised by Dongguan Yaxu (AiT) Technology Limited, personal only, and shall be noted in the revision of the document.

Testing..... :

Date of receipt of test item..... : Jun. 28, 2021

Date (s) of performance of tests..... : Jun. 28, 2021~ Jul. 01, 2021

Date of Issue..... : Jul. 02, 2021

Test Result..... : Pass

Compiled by (+ signature)..... : Simba Huang

Approved by (+ signature)..... : Seal Chen



Contents

	Page
COVER PAGE	
CONTENTS	2
1 TEST SUMMARY	3
1.1 MEASUREMENT UNCERTAINTY	4
2 TEST FACILITY	5
2.1 DEVIATION FROM STANDARD	5
2.2 ABNORMALITIES FROM STANDARD CONDITIONS	5
3 GENERAL INFORMATION	6
3.1 GENERAL DESCRIPTION OF EUT	6
3.2 TEST LOCATION	6
3.3 EUT TEST MODE	7
3.4 DESCRIPTION OF TEST SETUP	7
3.5 TEST PERIPHERAL LIST	8
3.6 EUT PERIPHERAL LIST	8
4 EQUIPMENTS LIST FOR ALL TEST ITEMS	9
5 RADIATED EMISSION MEASUREMENT	11
5.1.1 E.U.T. Operation	11
5.1.2 Test Specification	11
5.1.3 Measurement Data	12
5.1.4 Test Setup photograph	15
6 IMMUNITY TEST RESULTS	16
6.1 ELECTROSTATIC DISCHARGE IMMUNITY TEST	16
6.1.1 E.U.T. Operation	16
6.1.2 Test specification	16
6.1.3 Measurement Data	17
6.1.4 Test Setup Photograph	18
6.2 RF FIELD STRENGTH IMMUNITY TEST	19
6.2.1 E.U.T. Operation	19
6.2.2 Test specification	19
6.2.3 Measurement Data	20
6.3 POWER FREQUENCY MAGNETIC FIELD IMMUNITY TEST	22
6.3.1 E.U.T. Operation	22
6.3.2 Test specification	22
6.3.3 Measurement Data	23
6.3.4 Test Setup Photograph	21
7 APPENDIX-PHOTOGRAPHS OF EUT CONSTRUCTIONAL DETAILS	24

1 Test Summary

Test	Test Requirement	Test Method	Criterion	Result
Conducted Emission 150kHz to 30MHz	EN 55032:2015+A11:2020 EN 61000-6-3:2007+A1:2011	Clause 7 of CISPR 16-2-1	Limits	N/A
Radiated Emissions 30MHz to 1GHz 1GHz to 6GHz	EN 55032:2015+A11:2020 EN 61000-6-3:2007+A1:2011	Clause 7.3 of CISPR 16-2-3	Limits	PASS
Harmonics	EN IEC 61000-3-2:2019	EN IEC 61000-3-2:2019	Limits(A)	N/A
Flicker	EN 61000-3-3: 2013+A1:2019	IEC 61000-3-3:2013+A1:2017	Limits	N/A
Electrostatic Discharge	EN 55035: 2017+A11:2020 EN 61000-6-1:2019	IEC 61000-4-2:2008	B	PASS
R/S	EN 55035: 2017+A11:2020 EN 61000-6-1:2019	IEC 61000-4-3:2010	A	PASS
Electric Fast Transients	EN 55035: 2017+A11:2020 EN 61000-6-1:2019	IEC 61000-4-4: 2012	B	N/A
Surge	EN 55035: 2017+A11:2020 EN 61000-6-1:2019	IEC 61000-4-5:2017	B	N/A
C/S	EN 55035: 2017+A11:2020 EN 61000-6-1:2019	IEC 61000-4-6:2013	A	N/A
Power Frequency magnetic Field	EN 55035: 2017+A11:2020 EN 61000-6-1:2019	IEC 61000-4-8:2009	A	PASS
Dips	EN 55035: 2017+A11:2020 EN 61000-6-1:2019	IEC 61000-4-11:2017	B& C	N/A

Note:

1. "N/A" For products power by DC power, this item not applicable.

1.1 Measurement Uncertainty

The report uncertainty of measurement $y \pm U$, where expanded uncertainty U is based on a standard uncertainty Multiplied by a coverage factor of $k=2$, providing a level of confidence of approximately 95%.

No.	Item	Frequency Range	U , Value
1	Power Line Conducted Emission	150KHz~30MHz	1.20 dB
2	Disturbance Power Emission	30MHz~300MHz	2.96 dB
3	Radiated Emission Test	30MHz~1GHz	3.30 dB
4	Radiated Emission Test	1GHz~18GHz	3.30 dB

2 Test Facility

The test facility is recognized, certified or accredited by the following organizations:

.CNAS- Registration No: L6177

Dongguan Yaxu (AiT) technology Limited is accredited to ISO/IEC 17025:2017 general Requirements for the competence of testing and calibration laboratories (CNAS-CL01 Accreditation Criteria for the competence of testing and calibration laboratories) on Aug. 04, 2020

2.1 Deviation from standard

None

2.2 Abnormalities from standard conditions

None

3 General Information

3.1 General Description of EUT

EUT Name:	Lithium ion Battery
Model No:	JD-LK48-10
Derivative models:	N/A
Brand Name:	N/A
Serial No:	N/A
Power Supply Range:	48V 10Ah
Test Power Supply:	Charge: DC 54.6V from DC power supply Discharge: DC 48V from Lithium ion Battery

3.2 Test Location

All tests were performed at:

Dongguan Yaxu (AiT) Technology Limited

No. 22, Jin qianling Third Street, Jitigang, Huangjiang, Dongguan, Guangdong, China.

Tel.: +86.769.82020499 Fax.: +86.769.82020495

3.3 EUT Test Mode

Mode 1	The EUT is Charging.
Mode 2	The EUT is Discharging.

3.4 Description of Test setup

EUT was tested in normal configuration (Please See following Block diagrams)

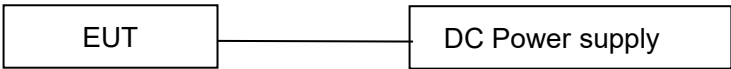
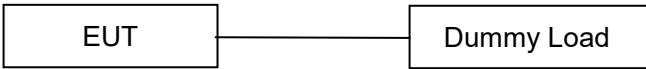
1. Block diagram of EUT configuration-EMI	
Mode 1:	 <pre> graph LR EUT1[EUT] --- DCPS[DC Power supply] </pre>
Mode 2:	 <pre> graph LR EUT2[EUT] --- DL[Dummy Load] </pre>
2. Block diagram of EUT configuration-EMS	
The same as above.	

3.5 Test Peripheral List

No.	Equipment	Manufacturer	EMC Compliance	Model No.	Serial No.	Power cord	signal cable
1	DC Power supply	Manson	N/A	HCS-3604	G521100129	N/A	N/A

3.6 EUT Peripheral List

No.	Equipment	Manufacturer	EMC Compliance	Model No.	Serial No.	Power cord	signal cable
1	N/A	N/A	N/A	N/A	N/A	N/A	N/A

4 Equipments List for All Test Items

<input checked="" type="checkbox"/> Radiation Test Equipment						
No	Test Equipment	Manufacturer	Model No	Serial No	Cal. Date	Cal. Due Date
1	EMI Measuring Receiver	R&S	ESR	101160	2020.08.28	2021.08.27
2	Low Noise Pre Amplifier	Tsj	MLA-10K01-B01-27	1205323	2020.08.28	2021.08.27
3	TRILOG Super Broadband test Antenna	SCHWARZBECK	VULB9160	9160-3206	2020.08.28	2021.08.27
4	50Ω Coaxial Switch	Anritsu	MP59B	6200264416	2020.08.28	2021.08.27
5	Spectrum Analyzer	ADVANTEST	R3182	150900201	2020.08.28	2021.08.27
6	Low Noise Pre Amplifier	Tsj	MLA-0120-A02-34	2648A04738	2020.08.28	2021.08.27
7	Broadband Horn Antenna	Schwarzbeck	BBHA 9120D	452	2020.08.28	2021.08.27

<input checked="" type="checkbox"/> ESD Test Equipment						
No	Test Equipment	Manufacturer	Model No	Serial No	Cal. Date	Cal. Due Date
1	ESD Simulator	Schaffner	NSG435	5866	2020.08.28	2021.08.27

<input checked="" type="checkbox"/> R/S Test Equipment						
No	Test Equipment	Manufacturer	Model No	Serial No	Cal. Date	Cal. Due Date
1	MXG analog signal generator	Agilent	N5181A	MY46240859	2020.08.28	2021.08.27
2	Power Amplifier	Schaffner	CBA9433	T43574	2020.08.28	2021.08.27
3	Power Amplifier	Schaffner	CBA9409	T43605	2020.08.28	2021.08.27
4	Logarithmic-periodic Antenna	Schwarzbeck	VULP9118E	820	2020.08.28	2021.08.27
5	Broadband Horn Antenna	Schwarzbeck	BBHA 9120LF	255	2020.08.28	2021.08.27
6	Power meter	Agilent	E4419B	MY45102079	2020.08.28	2021.08.27
7	Power sensor	Agilent	8481A	MY41097696	2020.08.28	2021.08.27
8	Power sensor	Agilent	8481A	MY41097697	2020.08.28	2021.08.27
9	RF Relay matrix	tsj	RFM-S621	04261	2020.08.28	2021.08.27

<input type="checkbox"/> PFMF Test Equipment						
No	Test Equipment	Manufacturer	Model No	Serial No	Cal. Date	Cal. Due Date
1	Magnetic field generator	Schaffner	MFO6501	34299	2020.08.28	2021.08.27
2	Magnetic Field Loop Antenna	Schaffner	INA 702	148	2020.08.28	2021.08.27

Note:

1. is not applicable in this Test Report. is applicable in this Test Report.

5 Radiated Emission Measurement

Limits of Radiated Emission Measurement (Below 1GHz)

Frequency (MHz)	<input type="checkbox"/> Class A (3m)	<input checked="" type="checkbox"/> Class B (3m)
	Quasi-Peak dB(μV/m)	
30 ~ 230	50.0	40.0
230 ~ 1000	57.0	47.0

Limits of Radiated Emission Measurement (Above 1GHz)

Frequency (MHz)	<input type="checkbox"/> Class A (3m)		<input type="checkbox"/> Class B (3m)	
	Peak dB(μV/m)	Average dB(μV/m)	Peak dB(μV/m)	Average dB(μV/m)
1000~3000	76	56	70	50
3000~6000	80	60	74	54

Detector:	Peak for pre-scan (120kHz resolution bandwidth)
	Quasi-Peak if maximum peak within 6dB of limit

5.1.1 E.U.T. Operation

Temperature:	26°C	Humidity:	55% RH	Atmospheric Pressure:	101	Kpa
Test Mode:	Mode 1/Mode 2		Worse Mode:	Mode 2		

5.1.2 Test Specification

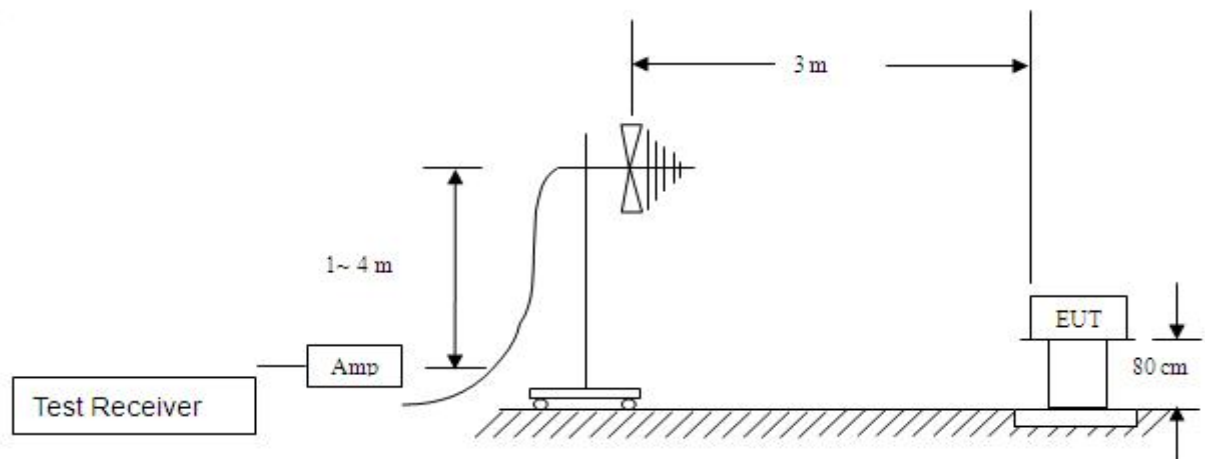

EUT was placed upon a wooden test table which was placed on the turn table 0.8m above the horizontal metal ground plane, and operating in the mode as mentioned above. A receiving antenna was placed 3m away from the EUT. During testing, turn around the turn table and move the antenna from 1m to 4m to find the maximum field-strength reading. All peripherals were placed at a distance of 10cm between each other. Both horizontal and vertical antenna polarities were tested.

5.1.3 Measurement Data

An initial pre-scan was performed in the 3m chamber using the spectrum analyzers in peak detection mode. The EUT was measured by Biology antenna with 2 orthogonal polarities and peak emissions from the EUT were detected within 6dB of the class B limit line.

The following quasi-peak measurements were performed on the EUT.

Model name:	JD-LK48-10	Test Date :	2021.07.01
Test Mode:	Mode 2	Phase :	Vertical
Test Voltage:	DC 48V		

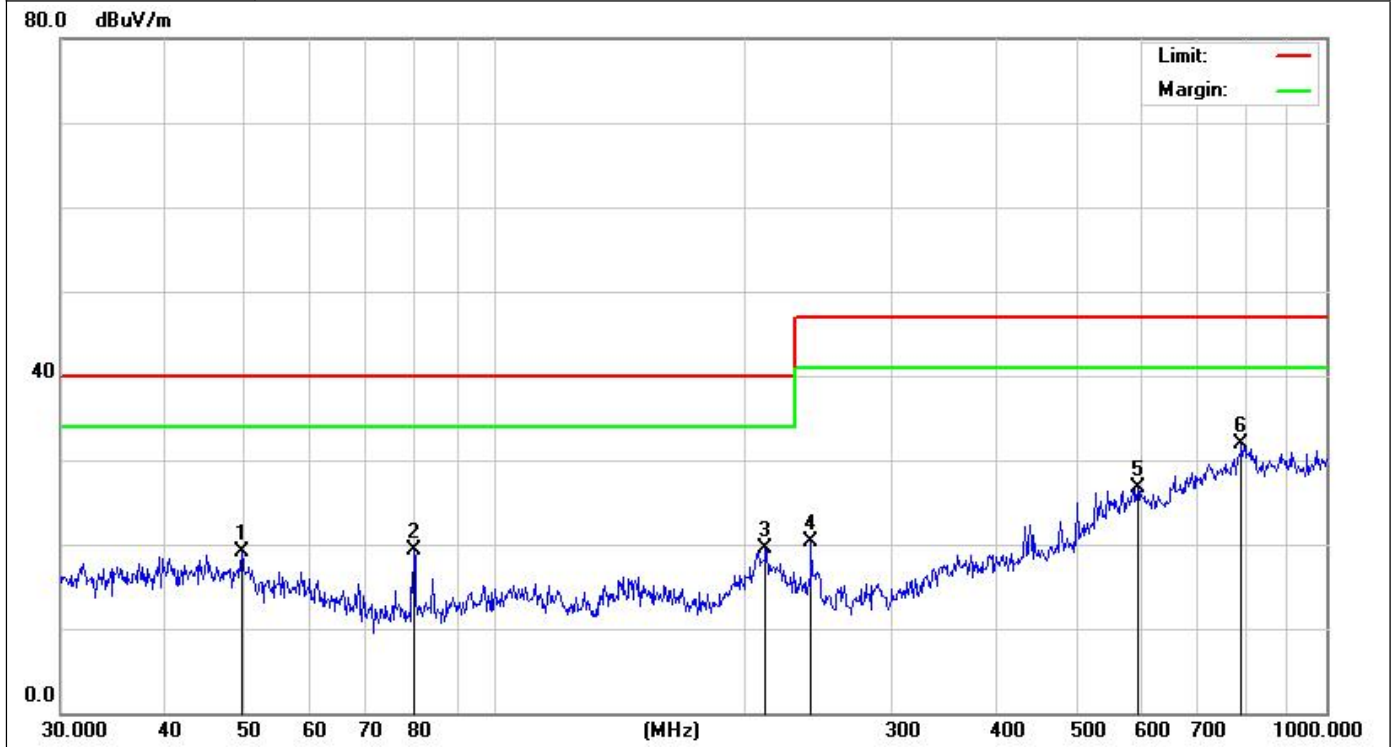

Remark: Factor = Antenna Factor + Cable Loss – Pre-amplifier.

No.	Mk.	Freq. MHz	Reading Level dBuV	Correct Factor dB	Measure- ment dBuV/m	Limit dBuV/m	Over dB	Detector
1		49.5328	25.09	-5.90	19.19	40.00	-20.81	peak
2		79.8003	30.54	-11.18	19.36	40.00	-20.64	peak
3		211.5265	23.69	-4.19	19.50	40.00	-20.50	peak
4		239.9874	26.74	-6.52	20.22	47.00	-26.78	peak
5		593.0497	24.31	2.48	26.79	47.00	-20.21	peak
6	*	790.6188	24.24	7.69	31.93	47.00	-15.07	peak

Model name:	JD-LK48-10	Test Date :	2021.07.01
Test Mode:	Mode 2	Phase :	Horizontal
Test Voltage:	DC 48V		

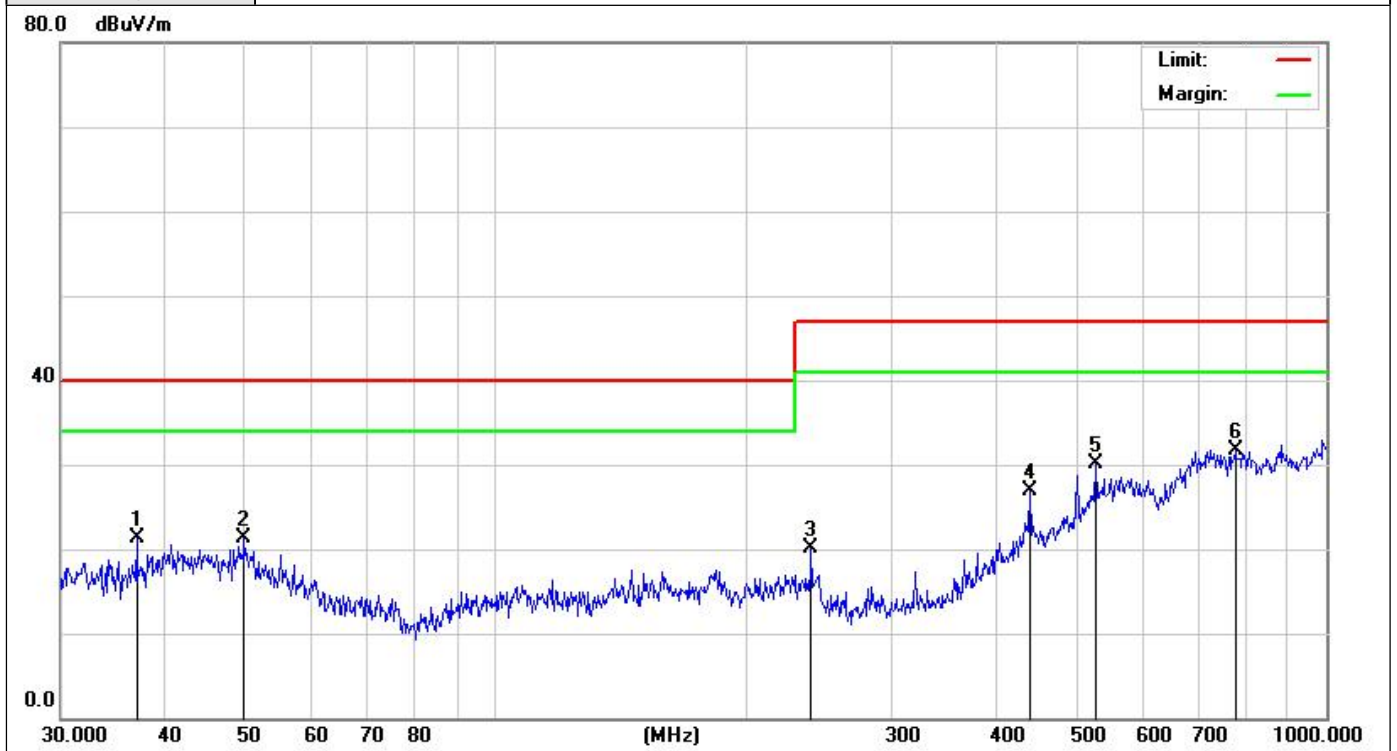

Remark: Factor = Antenna Factor + Cable Loss – Pre-amplifier.

No.	Mk.	Freq. MHz	Reading Level dBuV	Correct Factor dB	Measure- ment dBuV/m	Limit dBuV/m	Over dB	Detector
1		37.0248	24.34	-3.11	21.23	40.00	-18.77	peak
2		49.8814	24.58	-3.22	21.36	40.00	-18.64	peak
3		239.9874	26.57	-6.52	20.05	47.00	-26.95	peak
4		440.1963	27.57	-0.68	26.89	47.00	-20.11	peak
5		528.2458	26.19	3.83	30.02	47.00	-16.98	peak
6	*	776.8778	24.31	7.41	31.72	47.00	-15.28	peak

5.1.4 Test Setup photograph

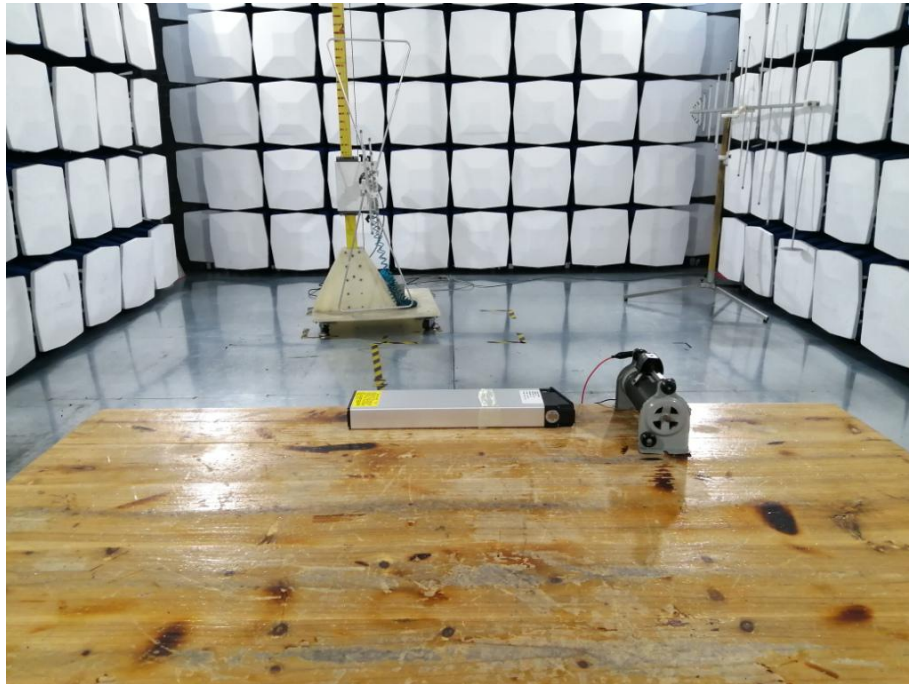

6 Immunity Test Results

6.1 Electrostatic discharge immunity test

Acceptable Performance Criterion:	B
Discharge Impedance:	330 Ω / 150 pF
Discharge Voltage:	Air Discharge: ±8 kV
	Contact Discharge: ±4kV
	VCP, HCP: ±4kV
Polarity:	Positive & Negative
Minimum discharge Interval:	1 second

6.1.1 E.U.T. Operation

Temperature:	26°C	Humidity:	55% RH	Atmospheric Pressure:	101	Kpa
Test Mode:	Mode 1/ Mode 2					

6.1.2 Test specification

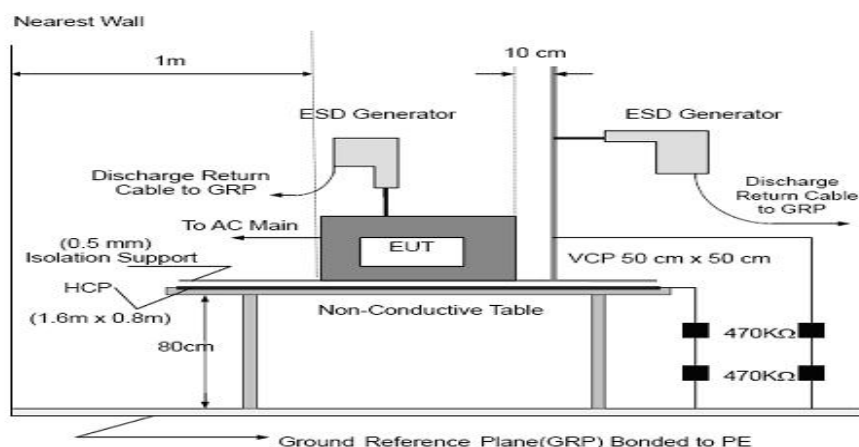

EUT was operated in the mode as mentioned above. Both contact and air discharge was executed. Contact discharge to the conductive surfaces and to coupling planes; air discharge at insulating surfaces. Each test point shall be subjected to 25 discharges at least (For each voltage and polarity).

6.1.3 Measurement Data

Test Record

Electrostatic Discharge Test Results																		
M/N:	JD-LK48-10										Test Result: <input checked="" type="checkbox"/> Pass <input type="checkbox"/> Fail							
Test Voltage:	Charge: DC 54.6V from DC power supply Discharge: DC 48V from Lithium ion Battery										Test date: 2021.07.01							
Discharge times	Contact discharge: minimum <u>25</u> times (+/--respectively) at each point, Air discharge: minimum <u>10</u> times (+/- respectively) at each point.																	
Discharge Mode	Air Discharge								Contact Discharge								Performance Criterion	Result
	4		8		10		15		2		4		6		8			
Test Location	+	-	+	-	+	-	+	-	+	-	+	-	+	-	+	-		
HCP											A	A					B	Pass
VCP											A	A						Pass
A1			A	A														Pass
Note: "P" means Pass, Horizontal Coupling Plane (HCP) and Vertical Coupling plane (VCP). "Cx" means Contact Point ,x=1~N, "Ax" means Air Point, x=1~N.																		

6.1.4 Test Setup Photograph



6.2 RF field strength immunity test

Acceptable Performance Criterion:	B
Test Level	3V/m
Test Distance	3 m
Frequency Range	80MHz~1000MHz, 1800 MHz ,2600MHz,3500 MHz, 5000 MHz, 1400~6000 MHz 3V/m
Polarity:	Horizontal & Vertical

6.2.1 E.U.T. Operation

Temperature:	26°C	Humidity:	55% RH	Atmospheric Pressure:	101	Kpa
Test Mode:	Mode 1/Mode 2					

6.2.2 Test specification

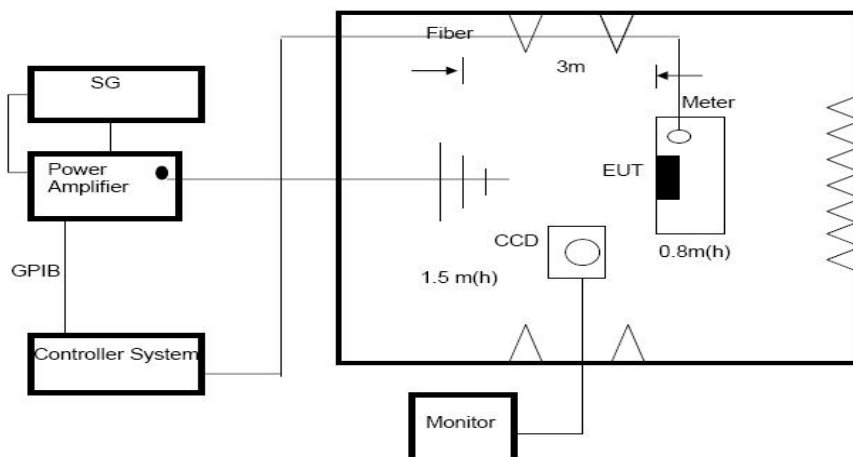

Test was executed in a fully Anechoic chamber. An antenna was used to transmit interference signal. EUT was placed upon a wooden table above the reference ground 0.8m, and was positioned so that the four sides of the EUT shall be exposed to the electromagnetic field in a sequence. In each position the performance of the EUT was investigated. A camera was used to monitor the loss of function or degradation of performance of the EUT.

6.2.3 Measurement Data

Test Record

Radiated Frequency Field Strength Susceptibility Results				
M/N:	JD-LK48-10	Test Result: <input checked="" type="checkbox"/> Pass <input type="checkbox"/> Fail		
Test Voltage:	Charge: DC 54.6V from DC power supply Discharge: DC 48V from Lithium ion Battery	Test date: 2021.07.01		
Test Port	Enclosure			
Operating Mode	Mode 1/Mode 2			
Test Level	<u>3</u> V/m(r.m.s) (unmodulated)		Criterion	A
Frequency Range(MHz)	Antenna polarity	Modulation	EUT position	Result
80~1000 1800 2600 3500 5000 1400~6000	Horizontal	1KHz, 80% AM	Front	Pass
			Rear	Pass
			Left	Pass
			Right	Pass
			Top	Pass
			Bottom	Pass
80~1000 1800 2600 3500 5000 1400~6000	Vertical	1KHz, 80% AM	Front	Pass
			Rear	Pass
			Left	Pass
			Right	Pass
			Top	Pass
			Bottom	Pass
Note: None				

6.2.4 Test Setup Photograph

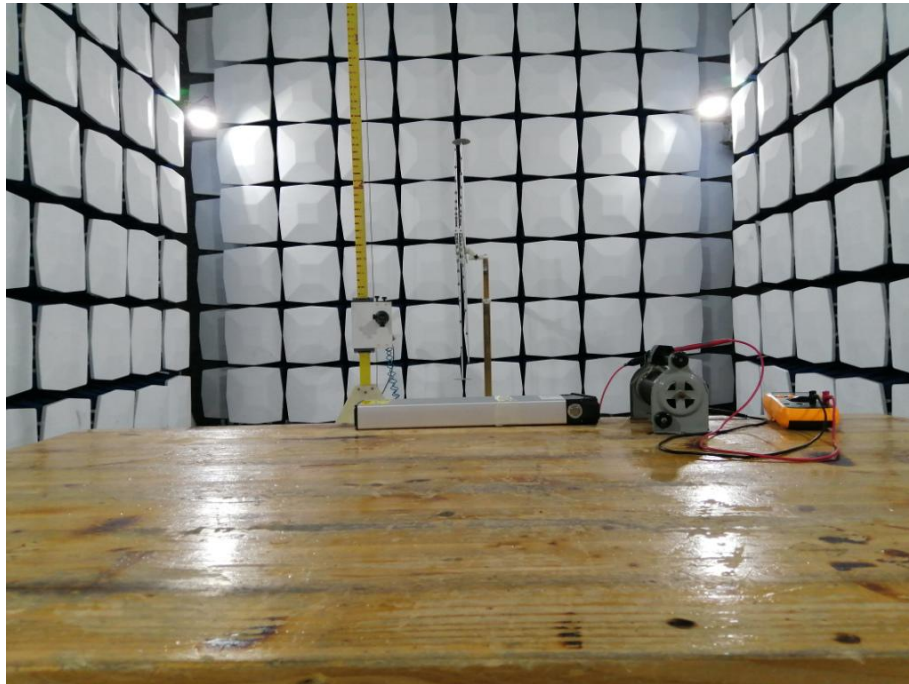

6.3 Power frequency magnetic field immunity test

Acceptable Performance Criterion:	A
Test Level:	1 A/m
Coil Orientation:	X & Y & Z
Test Duration:	5 Minutes for each orientation

6.3.1 E.U.T. Operation

Temperature:	26°C	Humidity:	55% RH	Atmospheric Pressure:	101	Kpa
Test Mode:	Mode 1/Mode 2					

6.3.2 Test specification

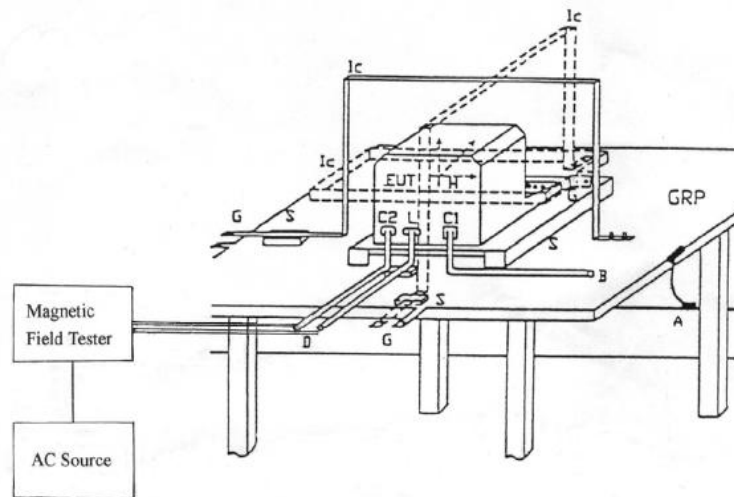

The equipment is configured and connected to satisfy its functional requirements. It was placed on the ground reference plane with the interposition of a 0.1 m thickness wooden support and was placed in the center of the induction coil. All cables (include power cord and signal line) were exposed to the magnetic field for at least 1m of their length.

6.3.3 Measurement Data

Pass.

Remark:

There is no need for Power Frequency Magnetic Field Immunity test to be performed on this product in accordance with EN 55035& EN61000-6-1 TABLE 1 because this product does not contain any devices susceptible to magnetic fields.

7 APPENDIX-Photographs of EUT Constructional Details

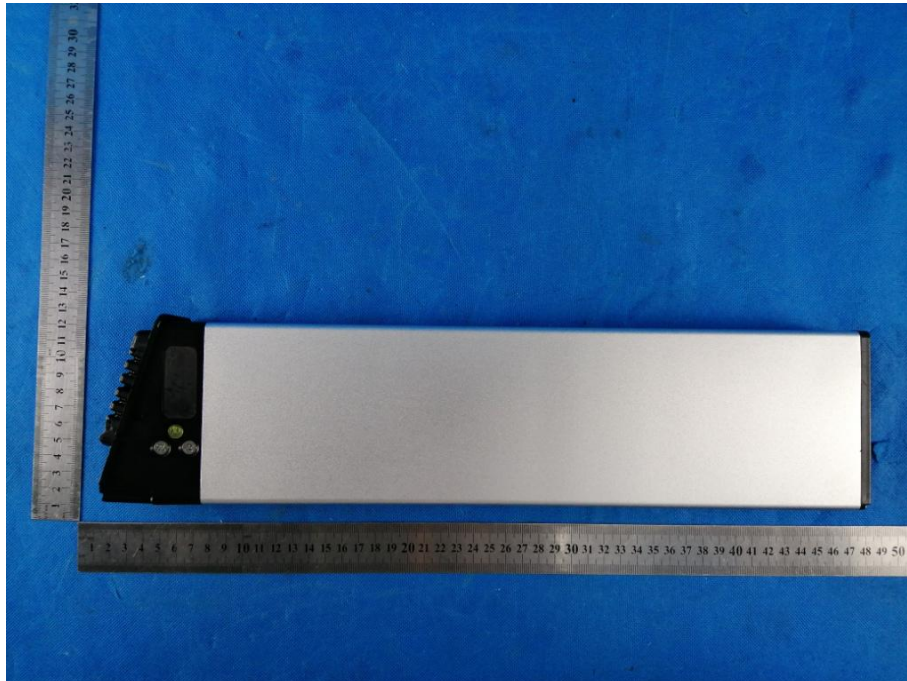
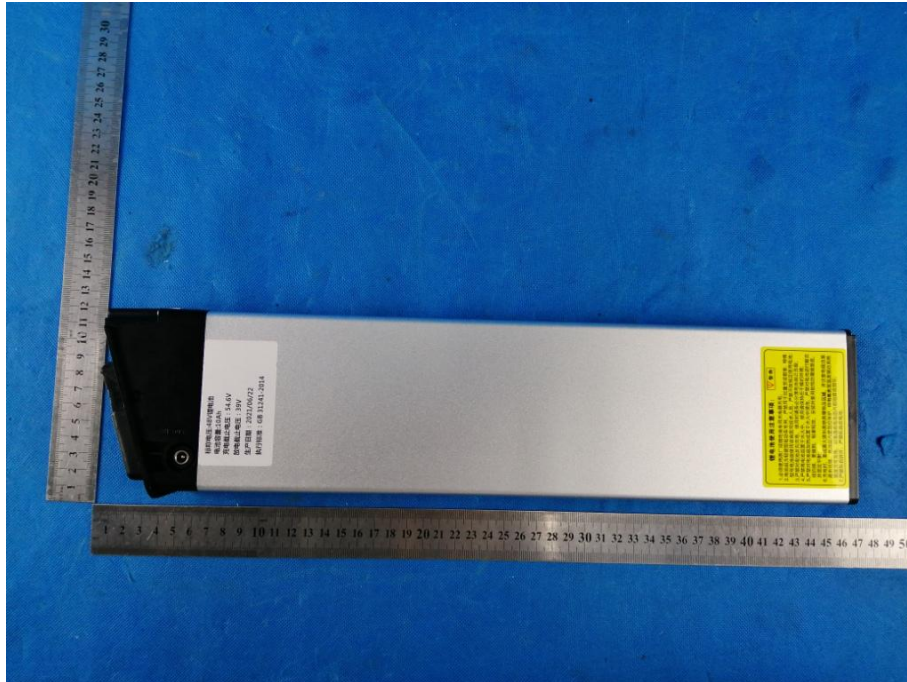

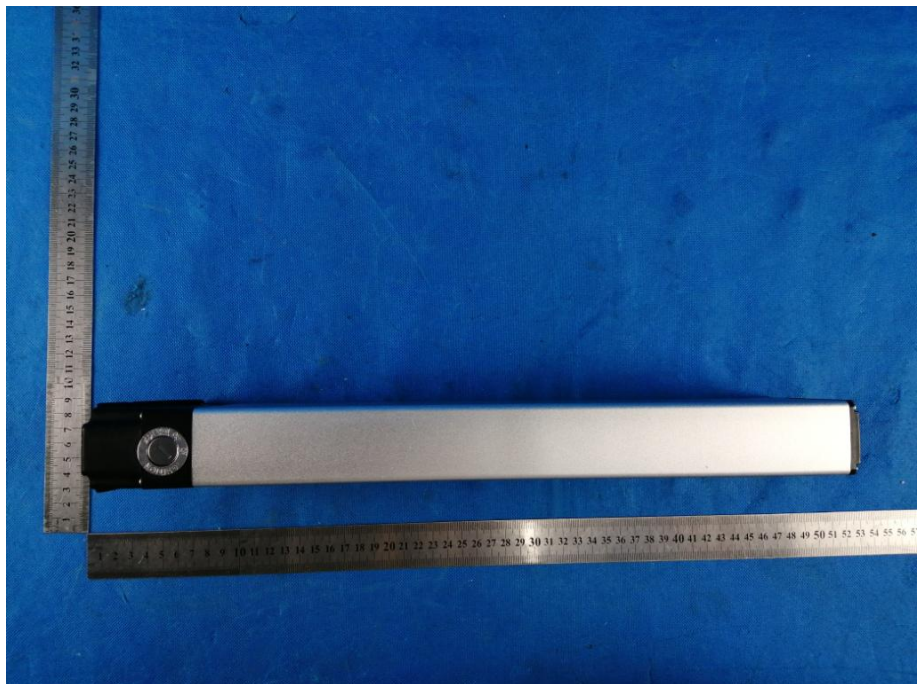
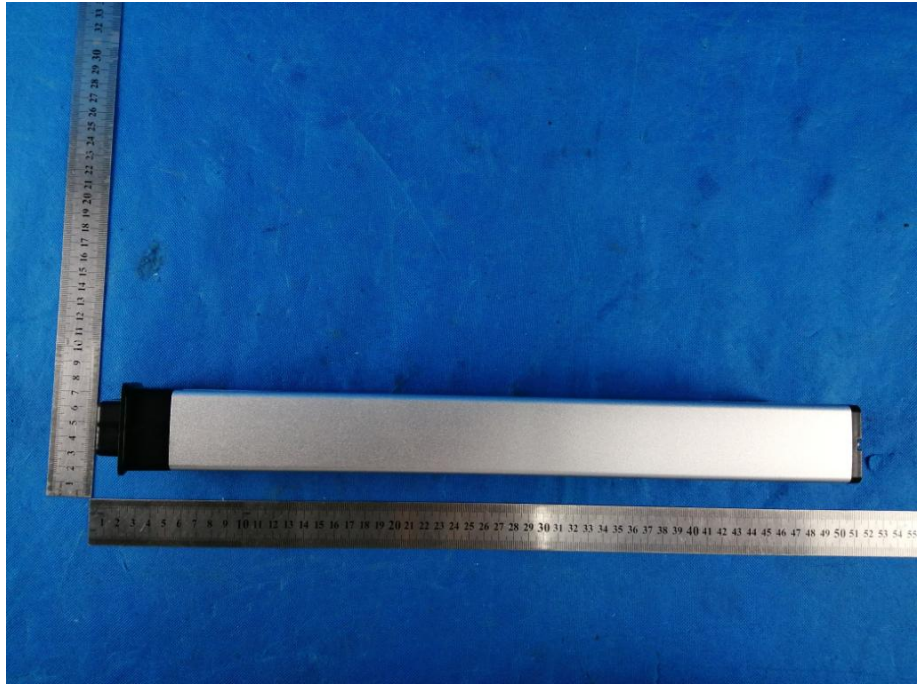

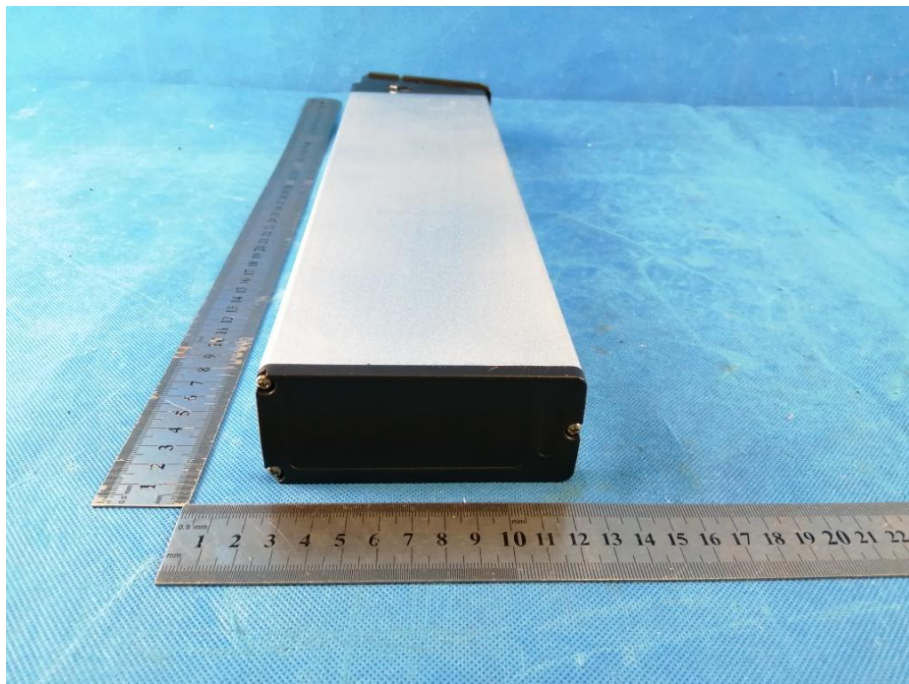

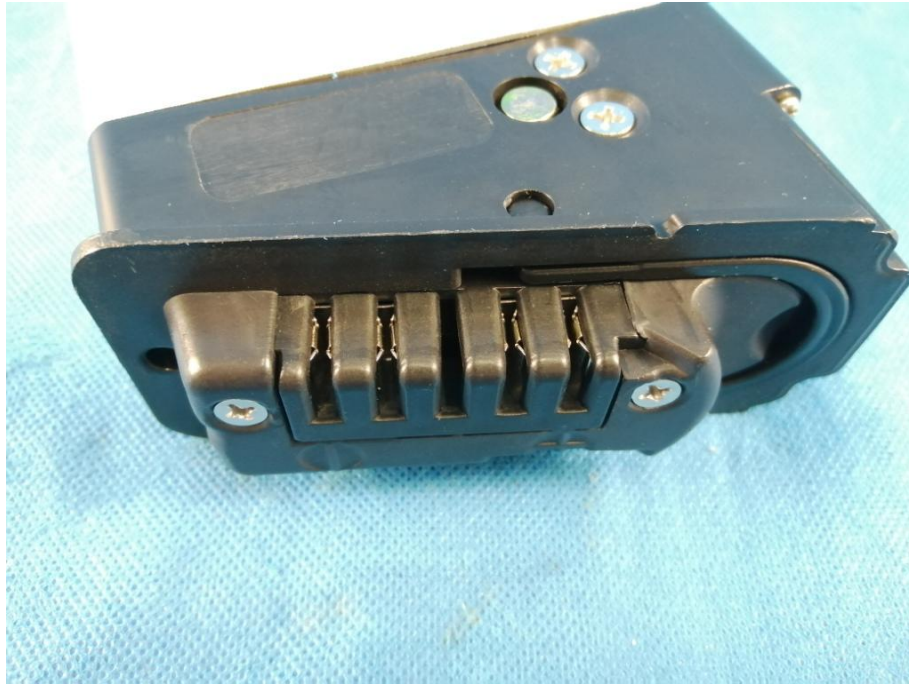

****End of report****